

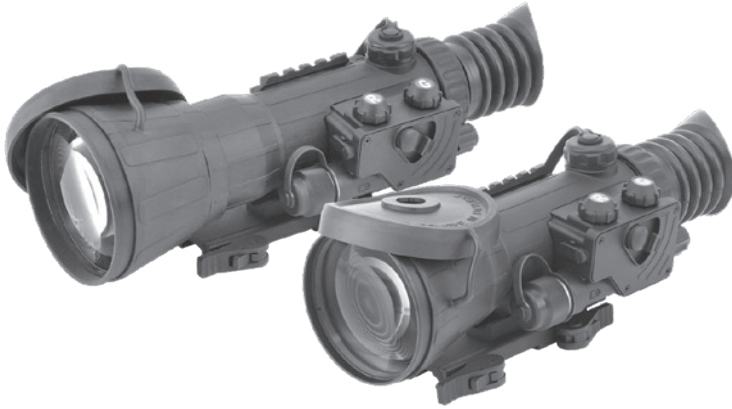

# VULCAN 4.5X VULCAN 6X VULCAN 8X

## Night Vision Riflescopes



## OPERATION AND MAINTENANCE MANUAL

**Important Export Restrictions!** Commodities, products, technologies and services of this manual are controlled by the U.S. Department of State Office of Defense Trade Controls, in accordance with International Traffic in Arms (ITAR), Title 22, Code of Federal Regulations Part 120-130 and/or by the Export Administration Regulations (EAR) of U.S. Department of Commerce. At any time when a license or a written approval of the U.S. Government is applicable to it, it is illegal and strictly forbidden to export, intend to export, transfer in any other manner whatsoever, sell any hardware or technical data, provide any associated service to any non-U.S. resident, beyond or within the United States territory, until the valid license or written approval has been issued by the Departments of the U.S. Government having jurisdiction. Additionally U.S. law prohibits the sale, transfer, or export of items to certain restricted parties, destinations, and embargoed countries, as identified on lists maintained by the U.S. Department of State, the U.S. Department of Commerce, and the U.S. Department of Treasury. It is the responsibility of the Customer to be aware of these lists. The sale, transfer, transportation, or shipment outside of the U.S. of any product prohibited or restricted for export without complying with U.S. export control laws and regulations, including proper export licensing, documentation or authorization, is unlawful and may result in civil and/or criminal penalties and/or constitute a federal crime. Diversion contrary to U.S. law is strictly prohibited.

## SAFETY SUMMARY

Before operating this product, carefully study this Operation and Maintenance Manual.

The Armasight Vulcan Night Vision Riflescope is a precision electro-optical instrument and requires careful handling. To avoid physical danger to the user and damage to the equipment, follow all WARNINGS, CAUTIONS, and NOTES.

Below are definitions of the alerts that will appear throughout this Manual:

**WARNING** – Identifies clear danger to the person operating the equipment.

**CAUTION** – Identifies risk of damage to the equipment.

**NOTE** – Highlights essential procedures, conditions, statements, and important instructional information for the user.



### WARNING:

Always make sure your firearm is unloaded before you place the scope on the firearm. Reconfirm that the chamber is empty if you stop the procedure then resume later. Safe handling rules should be followed at all times.



### WARNING:

If a scope is mounted too far to the rear, the eyepiece can injure the shooter's brow. Shooting at an uphill angle also increases this hazard because it shortens the distance between the brow and the rear of the scope. For this reason, Armasight scopes are engineered to provide generous eye relief. Therefore, when mounting your scope, we recommend positioning it as far forward in the mounts as possible to take full advantage of this generous eye relief. With hard-recoiling rifles, serious injury or even death can result from eyepiece impact with the shooter during the recoil process when discharging the firearm. Be certain that your installation provides sufficient eye relief for the recoil generated by your rifle before shooting the firearm.

NOTE: Give special attention to this warning when shooting uphill and/or from a prone position. These shooting conditions can dramatically reduce eye relief. PLEASE maintain maximum eye relief when shooting heavy recoiling and/or magnum firearms. THE USER ASSUMES ALL RESPONSIBILITY AND LIABILITY FOR HAVING THE ARMASIGHT RIFLESCOPE PROPERLY MOUNTED TO A FIREARM AND USING THE ARMASIGHT RIFLESCOPE PROPERLY. ALWAYS CHECK THE CONDITION OF YOUR MOUNTING SYSTEM PRIOR TO USING YOUR FIREARM.



### WARNING:

**This product contains natural rubber latex, which may cause allergic reactions!** The FDA has reported an increase in the number of deaths that are associated with an apparent sensitivity to natural latex proteins. If you are allergic to latex, it is a good idea to learn which products contain it and strictly avoid exposure to those products.

The information provided in this manual is for familiarization purposes only. The contents may undergo further changes with no commitment by Armasight® to notify customers of any updates.

Armasight® assumes no responsibility for any misprints or other errors that this manual may contain.

© Armasight Inc. 2013

**WARNING:**

- Armasight recommends the use of an eyecup on the scope's eyepiece. This will allow for both eyepiece adjustment and relief. Preferably, the eyecup should include a side paddle to help avoid detection.
- The light from the infrared illuminator is invisible to the naked eye. However, the light can be detected by other night vision devices.

**CAUTION:**

- Do not dismantle the equipment.
- Keep the equipment clean. Protect it from moisture, dramatic temperature changes, and electric shocks.
- Do not drop or hit the equipment.
- Protect the equipment from overexposure to light; do not activate the equipment in daylight with the objective lens cap removed; do not aim the equipment at bright light sources (fire, car headlights, lanterns, street lamps, room lights, etc.).
- Do not force the equipment controls past their stopping points.
- Do not leave the equipment on during breaks in operation.
- Verify that the equipment is off before installing a battery.
- Do not store the equipment with the battery still inserted.
- Clean and dry each item thoroughly before placing them into the storage case.

**NOTES:**

- The equipment requires some level of ambient light (moonlight, starlight, etc.) to function correctly.
- Performance of the device in nighttime conditions depends on the level of ambient light in the environment. Please remember the following:
  - The level of ambient light is reduced by the presence of clouds, shade, or objects that block natural light (trees, buildings, etc.).
  - The equipment is less effective when operated in shadows and other darkened areas.
  - The equipment is less effective when operated in rain, fog, sleet, snow, dust or smoke.
  - The equipment will not “see” through dense smoke.
- Retain all packaging materials in case any defective components need to be returned.

# LIST OF CONTENTS

TITLE	PAGE
<b>Safety Summary</b>	2
<b>List of Contents</b>	4
<b>List of Figures</b>	5
<b>List of Tables</b>	6
<b>How to Use This Manual</b>	6
<b>1. INTRODUCTION</b>	<b>7</b>
<b>1.1 General Information</b>	7
1.1.1 Type of Manual	7
1.1.2 Model Number and Equipment Name	7
1.1.3 Purpose of Equipment	7
1.1.4 Reporting Equipment Improvement Recommendations	7
<b>1.2 Warranty Information and Registration</b>	8
1.2.1 Warranty Information	8
1.2.2 Limitation of Liability	8
1.2.3 Product Warranty Registration	8
1.2.4 Obtaining Warranty Service	9
<b>1.3 Cross References</b>	9
<b>1.4 List of Abbreviations</b>	10
<b>2. DESCRIPTION AND DATA</b>	<b>11</b>
<b>2.1 System Description</b>	11
<b>2.2 Specifications</b>	13
<b>2.3 Standard Components</b>	15
<b>2.4 Optional Equipment</b>	16
<b>2.5 Key Features</b>	17
<b>2.6 System Limitations</b>	17
<b>3. OPERATING INSTRUCTIONS</b>	<b>18</b>
<b>3.1. Installation and Mounting</b>	18
3.1.1 Vulcan Battery Installation	18
3.1.2 XLR-IR850 Battery Installation	19
3.1.3 Installing the Vulcan on a Weapon	19
3.1.4 Clamping Device Adjustment	20
3.1.5 Fastening an Advanced Wireless Remote Control to a Weapon	21
3.1.6 Installing the XLR-IR850	21
<b>3.2 Controls and Indicators</b>	22
3.2.1 Vulcan Controls and Indicators	22
3.2.2 XLR-IR850 Controls	24
<b>3.3 Operating Procedures</b>	24
3.3.1 Boresight Adjustment Procedure	24
3.3.2 Vulcan Operating Procedures	25
3.3.3 Operating XLR-IR850	26
3.3.4 Operating in Changing Light Conditions	27
3.3.5 Shut-Down	27

<b>4. PREVENTIVE MAINTENANCE AND TROUBLESHOOTING</b>	<b>28</b>
<b>4.1 Preventive Maintenance Checks and Services</b>	28
4.1.1 Preventive Maintenance Checks and Services (PMCS)	28
<b>4.2 Operator Troubleshooting</b>	30
<b>4.3 Identification of Operational Defects</b>	31
4.3.1 Operational Defects	31
4.3.2 Cosmetic Blemishes	31
<b>4.4 Maintenance</b>	33
4.4.1 General	33
4.4.2 Cleaning Procedures	33
4.4.3 Battery Removal and Replacement	34
<b>4.5 Return Instructions</b>	34
<b>APPENDIX</b>	<b>35</b>
<b>A. Estimation of Ambient Illumination Level</b>	35
<b>B. Vulcan List of Spare Parts</b>	35
<b>C. Product Warranty Registration Card</b>	36

## LIST OF FIGURES

FIGURE	TITLE	PAGE
2-1	Vulcan Night Vision Riflescopes	11
2-2	Vulcan Night Vision Rifle scope	12
2-3	Standard Components	15
24	Vulcan Optional Equipment	16
3-1	Vulcan. Battery Installation	18
3-2	Battery Adapter Positions in the Battery Cap	19
3-3	XLR-IR850. Battery Installation	19
3-4	Vulcan Mount. Top View	20
3-5	Vulcan Mount. Underside View	20
3-6	Clamping Device Adjustment	20
3-7	Advanced Wireless Remote Control	21
3-8	XLR-IR850 Illuminator	21
3-9	Vulcan Controls	23
3-10	Mil-Dot Reticle	23
3-11	XLR-IR850 Controls	24
3-12	Windage and Elevation Adjustment Turrets	25
3-13	XLR-IR850 Illuminator with Afocal Doubler	27
4-1	Shading	31
4-2	Edge Glow	31
4-3	Emission Points and Bright Spots	32
4-4	Fixed Pattern Noise	32
4-5	Chicken Wire	33
4-6	Advanced Wireless Remote Control. Battery Installation	34
B-1	Vulcan Spare Parts	35

## LIST OF TABLES

TABLE	TITLE	PAGE
2-1	System Description	13
2-2	Optical Data	13
2-3	Mechanical Data	13
2-4	Electrical Data	13
2-5	Environmental Data	14
2-6	XLR-IR850 Data	14
2-7	Advanced Wireless Remote Control (AWREC) Data	14
2-8	Standard Components	15
2-9	Vulcan Optional Equipment	16
3-1	Vulcan Controls and Indicators	22
3-2	IR850 Controls	24
4-1	Preventive Maintenance Checks and Services	28
4-2	Operator Troubleshooting	30
A-1	Standard Natural Light Conditions and Illumination Values	35
B-1	Vulcan Spare Parts List	36

## HOW TO USE THIS MANUAL

### USAGE

You must familiarize yourself with this entire manual before operating the equipment. Before performing any kind of maintenance on your device, read the section on maintenance in its entirety. Follow all WARNINGS, CAUTIONS, and NOTES.

### MANUAL OVERVIEW

The Manual contains sections on operating and maintaining the Vulcan Night Vision Riflescope. Throughout this Manual, the Armasight Vulcan Night Vision Riflescope will be referred to as the Vulcan, "the equipment," or "the device."

Reference data for the estimation of ambient illumination levels can be found in Appendix A.

A list of spare parts appears in Appendix B.

The Product Warranty Registration Card is located in Appendix C.

# INTRODUCTION

## 1.1 GENERAL INFORMATION

### 1.1.1 TYPE OF MANUAL

Operation and Maintenance (including a List of Spare Parts).

### 1.1.2 MODEL NUMBER AND EQUIPMENT NAME

**Armasight Vulcan 4.5X** Night Vision Riflescope.

**Armasight Vulcan 4.5X MG** Night Vision Riflescope with manual gain control.

**Armasight Vulcan 6X** Night Vision Riflescope.

**Armasight Vulcan 6X MG** Night Vision Riflescope with manual gain control.

**Armasight Vulcan 8X** Night Vision Riflescope.

**Armasight Vulcan 8X MG** Night Vision Riflescope with manual gain control.

### 1.1.3 PURPOSE OF EQUIPMENT

The Vulcan is a night vision weapon sight that provides excellent target acquisition and aiming capabilities for the demanding sports shooter, game hunter, military, law enforcement, or security personnel.

The Vulcan has multicoated, all-glass lenses and an internally adjustable fine reticle that makes precise shot placement incredibly easy. This night vision riflescope is also water, dust and sand-proof for increased reliability. Complete with tactical rails for lasers or illuminators (high power IR illuminator included as standard), the Armasight Vulcan is ideal for hunters, tactical marksmen, or anyone that needs a compact and light night vision riflescope.

The Vulcan sits on an adjustable, quick-release mount that will fit any Weaver or Picatinny rail, and can be mounted in seconds without tools.

The long-range XLR-IR850 infrared illuminator (referred to as the XLR-IR850 throughout this manual) enables use of the Vulcan in extremely low light conditions or total darkness. Other additional equipment, such as an infrared laser, red dot sight, etc., may also be installed on the Vulcan top Weaver rail.

### 1.1.4 REPORTING EQUIPMENT IMPROVEMENT RECOMMENDATIONS

Recommendations for improvements to the device are encouraged.

Mail your comments to:

Armasight Inc.

815 Dubuque Avenue

South San Francisco, CA 94080

USA

Or, send an email to [info@armasight.com](mailto:info@armasight.com).

## 1.2 WARRANTY INFORMATION AND REGISTRATION

### 1.2.1 WARRANTY INFORMATION

This product is guaranteed to be free from manufacturing defects in material and workmanship under normal use for a period of two (2) years from the date of purchase. In the event that a defect covered by the below warranty occurs during the applicable period stated above, Armasight, at its discretion, will either repair or replace the product; such action on the part of Armasight shall be the full extent of Armasight's liability, and the Customer's sole and exclusive reparation. This warranty does not cover a product if it has (a) been used in ways other than its normal and customary manner; (b) subjected to misuse; (c) subjected to alterations, modifications or repairs by the Customer or by any party other than Armasight without prior written consent of Armasight; (d) special order or "close-out" merchandise or merchandise sold "as-is" by either Armasight or the Armasight dealer; or (e) merchandise that has been discontinued by the manufacturer and either parts or replacement units are not available due to reasons beyond the control of Armasight. Armasight shall not be responsible for any defects or damage that in Armasight's view are a result from the mishandling, abuse, misuse, improper storage or improper operation of the device, including use in conjunction with equipment that is electrically or mechanically incompatible with, or of inferior quality to, the product, as well as failure to maintain the environmental conditions specified by the manufacturer. THE CUSTOMER IS HEREBY NOTIFIED THAT OPERATION OF THE EQUIPMENT DURING DAYLIGHT HOURS OR UNDER ANY EXCESSIVE LIGHT CONDITIONS MAY PERMANENTLY DAMAGE THE INTERNAL COMPONENTS OF THE UNIT AND SAID DAMAGE WILL NOT BE COVERED UNDER THIS WARRANTY. This warranty is extended only to the original purchaser. Any breach of this warranty shall be enforced unless the customer notifies Armasight at the address noted below within the applicable warranty period.

The customer understands and agrees that except for the foregoing warranty, no other warranties written or oral, statutory, expressed or implied, including any implied warranty of merchantability or fitness for a particular purpose, shall apply to the product. All such implied warranties are hereby and expressly disclaimed.

### 1.2.2 LIMITATION OF LIABILITY

Armasight will not be liable for any claims, actions, suits, proceedings, costs, expenses, damages or liabilities arising out of the use of this product. Operation and use of the product are the sole responsibility of the Customer. Armasight's sole undertaking is limited to providing the products and services outlined herein in accordance with the terms and conditions of this Agreement. The provision of products sold and services performed by Armasight to the Customer shall not be interpreted, construed, or regarded, either expressly or implied, as being for the benefit of or creating any obligation toward any third party of legal entity outside Armasight and the Customer; Armasight's obligations under this Agreement extend solely to the Customer. Armasight's liability hereunder for damages, regardless of the form or action, shall not exceed the fees or other charges paid to Armasight by the customer or customer's dealer. Armasight shall not, in any event, be liable for special, indirect, incidental, or consequential damages, including, but not limited to, lost income, lost revenue, or lost profit, whether such damages were foreseeable or not at the time of purchase, and whether or not such damages arise out of a breach of warranty, a breach of agreement, negligence, strict liability or any other theory of liability.

### 1.2.3 PRODUCT WARRANTY REGISTRATION

In order to validate the warranty on your product, Armasight must receive a completed Product Warranty Registration Card for each unit, or the Customer can complete a warranty registration on our website, at [www.armsight.com](http://www.armsight.com). Please complete the included form (Appendix C) and immediately mail it to our Service Center:

Armasight Inc.  
815 Dubuque Avenue  
South San Francisco, CA 94080  
USA



## 1.2.4 OBTAINING WARRANTY SERVICE

To obtain warranty service on your unit, the End-User (Customer) must notify the Armasight service department via email. Send any requests to [service@armasight.com](mailto:service@armasight.com) to receive a Return Merchandise Authorization number (RMA). When returning any device, please take in the product to your retailer, or send the product, postage paid and with a copy of your sales receipt, to Armasight Corporation's service center at the address listed above. All merchandise must be fully insured with the correct postage; Armasight will not be responsible for improper postage or merchandise that becomes lost or damaged during shipment. When sending product back, please clearly write the RMA# on the outside of the shipping box. Please include a letter that indicates your RMA#, the Customer's Name, a Return Address, reason for the return, contact information (valid telephone numbers and/or an e-mail address), and proof of purchase that will help us to establish the valid start date of the warranty. Product merchandise returns that do not have an RMA# listed may be refused, or a significant delay in processing may occur. Estimated Warranty service time is 10-20 business days. The End-User/ Customer is responsible for postage to Armasight for warranty service. Armasight will cover return postage/ shipping after warranty repair to the End-User/ Customer only if the product is covered by the aforementioned warranty. Armasight will return the product after warranty service by domestic UPS Ground service and/ or domestic mail. Should any other requested, required or international shipping methods be necessary, the postage/ shipping fee will be the responsibility of the End-User/ Customer.

## 1.3 CROSS REFERENCES

### COMMON NAME

Allen Wrench  
Battery Compartment  
Shipping Case  
Cotton Swab  
Neoprene Jack Plug  
O-Ring  
Safety Screw  
Pattern Generator  
Lens Covers  
Paddle Switch  
Batteries  
Technical Manual  
Tape Fastener Loop  
Tape Fastener Hook

### OFFICIAL NAME

Socket Head Screw Key  
Battery Box Cover  
Textile Bag  
Disposable Applicator  
Plug Assembly  
Gasket  
Electrical Dial-Knob Lock  
Optical Instrument Reticle  
Exit Port Covers  
Remote Cable Switch  
AA  
Operator and Field Maintenance Manual  
Fastener, Loop Tape  
Fastener, Hook Tape

## 1.4 LIST OF ABBREVIATIONS

C	Celsius (Centigrade)
CCW	counterclockwise
Cont'd	Continued
CW	clockwise
Dia	diameter
F	Fahrenheit
FOV	Field of View
g	gram
Gen	Generation
H	Height
hr	hour
IR	infrared
IT	Intensifier Tube
L	Length
LED	Light Emitting Diode
lx	lux
m	meter
mA	milliampere
min	minute
mm	millimeter
mW	milliwatt
nm	nanometer
No	Number
NV	Night Vision
NVD	Night Vision Device
Para	Paragraph
PMCS	Preventive Maintenance Checks and Services
QRM	Quick Release Mount
QTY	Quantity
RMA#	Return Merchandise Authorization number
s	second
seq	sequence
SR	Service Representative
VDC	Volts Direct Current
V	Volt
W	Width

# DESCRIPTION AND DATA

## 2.1 SYSTEM DESCRIPTION

The Vulcan consists of two primary parts: the night vision device (hereafter referred to as the NVD), and the quick-release mount system, or mount. The Vulcan is delivered already assembled; the mount should be secured to the NVD with two screws.

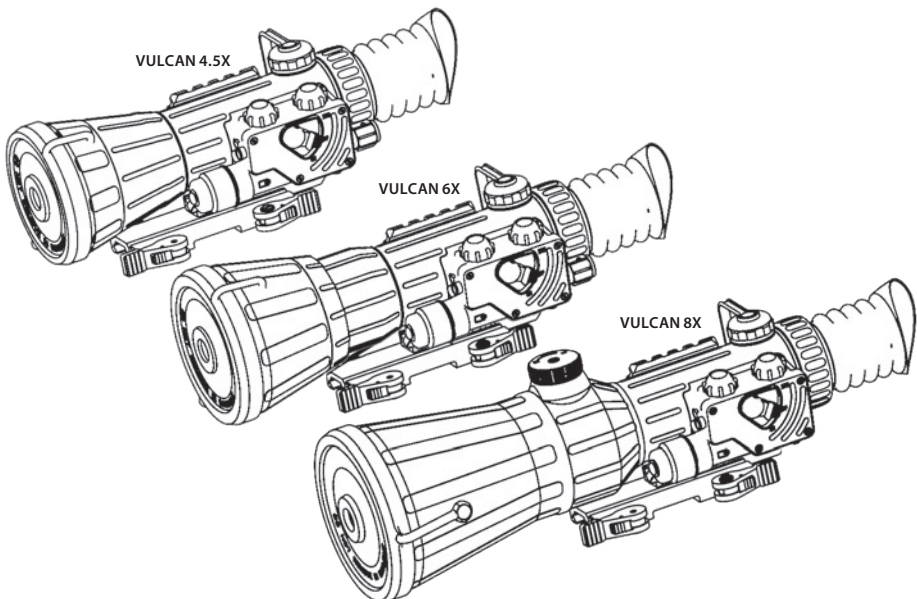

**FIGURE 2-1. VULCAN SERIES NIGHT VISION RIFLESCOPES**

The optical-electronic system of the NVD includes four main components: the objective lens, eyepiece, an intensifier tube, and the control compartment.

The intensifier tube (IT) amplifies the environment's ambient light using a photocathode input lens, which converts light waves and produces a visible image of the scene on the device's screen. The image is projected by the eyepiece.

The automatic brightness adjustment system maintains consistent image brightness, even in changing light conditions.

The MG versions of Vulcan incorporates manual gain control, which allows the operator to adjust the brightness of the image to compensate for overly bright or extremely dark conditions.

The bright light protection system controls existing ambient light through a photoreceiver, and cuts off the IT automatically when the illumination level exceeds the limit of 100-150lx within 20 seconds. The Vulcan turns back on when removed from the excessive light.

Automatic shut-off system automatically turns off the device when it is unused (controls are not touched) for 60 minutes. The automatic shut-off function preserves battery life should the device be inadvertently activated.

For optimal contrast, the Vulcan uses an illuminated red cross reticle with adjustable brightness.

The Vulcan is powered by a single AA or CR123A battery. A flashing reticle indicates low battery life.

The Picatinny/ Weaver mount (B) has an adjustable lever-cam clamping device for easy, quick, and reliable mounting and removal.

The Vulcan standard set also includes an XLR-IR850 long-range infrared illuminator equipped with a Weaver mount.

The Vulcan is shown in Figure 2-2. The ITEM NO. column in Table 2-1 indicates the number used to identify items in Figure 2-2.

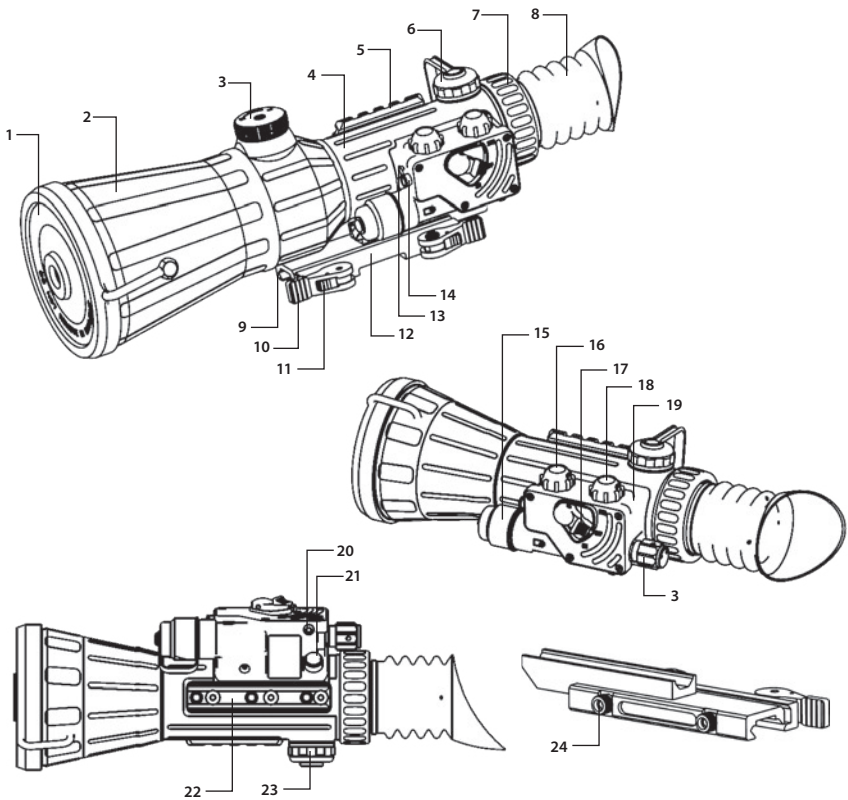

**FIGURE 2-2. VULCAN NIGHT VISION RIFLESCOPE**

**TABLE 2-1. SYSTEM DESCRIPTION**

ITEM	DESCRIPTION	ITEM	DESCRIPTION
1	Objective Lens Cap	12	Clamp
2	Lens	13	Photoreceiver
3	Focus Adjustment Knob	14	Pivoted Shutter
4	Main Body	15	Battery Cap with Battery Adapter
5	Weaver Rail	16	Reticle Brightness Adjustment Knob
6	Elevation Adjustment Turret Cap	17	Turn Switch
7	Eyepiece Ring	18	Gain Control Knob (only MG models)
8	Eye Cup	19	Control Compartment
9	Double Lever-Lock Quick Release Picatinny Mount	20	Purge Screw
10	Cam Lever	21	Rail
11	Lever Holder	22	Windage Adjustment Turret Cap
		24	Nut

## 2.2 SPECIFICATIONS

**TABLE 2-2. OPTICAL DATA**

ITEM	VULCAN 4.5X	VULCAN 6X	VULCAN 8X
Magnification	4.5x	6x	8x
Objective Lens Focal Length	108 mm	145 mm	192 mm
Objective Lens F/number	1:1.54	1:1.8	1:2.13
Field of View	9°	7°	5.4°
Exit Pupil Diameter	7 mm	7 mm	7 mm
Eye Relief	45 mm	45mm	45 mm
Focus Range	10 m	25 m	50 m
Diopter Adjustment	-4 to +4 diopters	-4 to +4 diopters	-4 to +4 diopters
Elevation/Windage Adjustment Range (min)	± 45 MOA	± 33 MOA	± 25 MOA
Elevation/Windage Adjustment Increment	17 SOA	12 SOA	9 SOA

**TABLE 2-3. MECHANICAL DATA**

ITEM	VULCAN 4.5X	VULCAN 6X	VULCAN 8X
Dimensions	(219×99×81) mm / (8.6×3.9×3.2) in	(246×104×91) mm / (9.7×4.1×3.6) in	(310×108×103) mm / (12.2×4.2×4.1) in
Weight	0.97 kg / 2.1 lbs	1.09 kg / 2.4 lbs	1.43 kg / 3.1 lbs

**TABLE 2-4. ELECTRICAL DATA**

ITEM	DATA
Battery	Single CR123A Lithium 3V, or AA Alkaline 1.5V, or any AA or CR123 type rechargeable batteries with voltage from 1.2V to 3.2V
Battery Life at 20°C	Up to 50 hr (3V) / 46 hr (1.5V)

**TABLE 2-5. ENVIRONMENTAL DATA**

ITEM	DATA
Operating Temperature	(-40 to +50)°C / (-40 to 122)°F
Storage Temperature	(-50 to +70)°C / (-58 to 158)°F
Illumination Required	Natural night illumination (overcast starlight to moonlight)
Immersion	1 m for 30 minutes
MIL-STD-810	Complies

**TABLE 2-6. XLR-IR850 ILLUMINATOR DATA**

ITEM	DATA
IR Emitter Type	LED
Power	1000 mW
Peak Wavelength	850 nm
Illumination Range	Up to 1000 m
Divergence	4 to 35°
Battery	Single 18650 Rechargeable Battery (3.7V) *
Battery Life at 20°C (68°F)	Up to 10 (1/4 Power); 8 (1/2 Power); 6 (3/4 Power); 2.5 (Full Power)
Overall Dimensions (with Mount)	(150×48×57) mm / (5.9×1.9×2.2) in
Weight (with Mount, w/o Battery)	264 g / 9.3 oz
Operating Temperature	(-20 to +50)°C / (-4 to 122)°F
Storage Temperature	(-50 to +70)°C / (-58 to 158)°F
Environmental Rating	Water and Fog Resistant

\* 18650 rechargeable battery and charger are included

**TABLE 2-7. ADVANCED WIRELESS REMOTE CONTROL (AWREC) DATA**

ITEM	DATA
Type	Wireless Remote Control
Working Range	Up to 0.5m
Battery	Single CR2032 Lithium battery (3V)
Battery Life at 20°C (68°F)	Approx. 10,000 clicks
Overall Dimensions	(48×39×18) mm / (1.9×1.5×0.7) in
Weight (with Battery)	25 g / 0.9 oz
Operating Temperature	(-30 to +50)°C / (-22 to 122)°F
Storage Temperature	(-50 to +70)°C / (-58 to 158)°F
Environmental Rating	Water and Fog Resistant

## 2.3 STANDARD COMPONENTS

The Vulcan standard components are shown in Figure 2-3 and listed in Table 2-8. The ITEM NO. column indicates the number used to identify items in Figure 2-3.

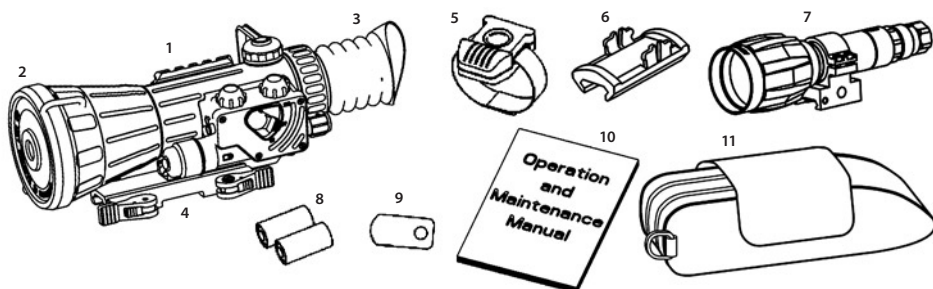

FIGURE 2-3. VULCAN STANDARD COMPONENTS

TABLE 2-8. VULCAN STANDARD COMPONENTS

ITEM NO.	DESCRIPTION	QUANTITY
1	<b>Vulcan Night Vision Riflescope</b> The night vision device equipped with quick-release mount.	1
2	<b>Lens Cap</b> A cap used to protect the lens and to be used when testing the unit in daylight.	1
3	<b>Eye-cup</b> A rubber cup used to protect the eyepiece as well as provide comfort for the operator.	1
4	<b>Double Lever-Lock Quick Release Picatinny Mount</b> A quick-release mount used to install the Vulcan on a Picatinny/ Weaver rail.	1
5	<b>Advanced Wireless Remote Control</b> Wireless control used to operate the Vulcan in short-time activation mode. Ensures quick and silent Vulcan activation/ deactivation. Delivered with CR2032 (3V) battery installed.	1
6	<b>Picatinny Adaptor for Advanced Wireless Remote Control</b> An adaptor mounted to the Picatinny rail of a weapon. Allows the Advanced Wireless Remote Control to be installed on the weapon.	1
7	<b>XLR-IR850 Detachable Wide Angle Adjustable X-Long-Range Infrared Illuminator</b> A detachable LED long-range infrared illuminator with a wide, adjustable beam angle. Compatible with night vision devices that rely on CCD or image intensifier technology. Should be used when there is little to no ambient light. Comes fully assembled with a dedicated mount in order to be installed on a Picatinny/Weaver rail. 18650 rechargeable battery and Charger are included.	1
8	<b>CR123A Battery</b> A single CR123A lithium battery used to power the Vulcan.	1

TABLE 2-8. CONTINUED

ITEM NO.	DESCRIPTION	QUANTITY
9	<b>Special Wrench</b> An instrument used for repositioning the battery adapter in the Vulcan battery cap, depending on the battery being installed.	1
10	<b>Carrying Case</b> A protective case used for storing and carrying the Vulcan and its accessories.	1
11	<b>Operation and Maintenance Manual</b> Provides safety information, equipment description, mounting procedures, operating instructions, and preventive maintenance checks and services (including a List of Spare Parts).	1

## 2.4 OPTIONAL EQUIPMENT

Optional items are shown in Figure 2-4 and listed in Table 2-9.

The PART NO. column indicates the primary number used by the manufacturer to identify an item.

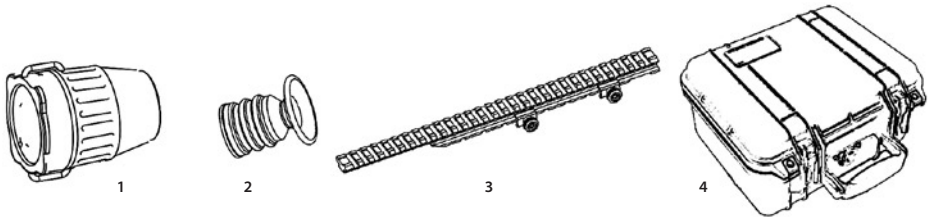

FIGURE 2-4. VULCAN OPTIONAL EQUIPMENT

TABLE 2-9. VULCAN OPTIONAL EQUIPMENT

ITEM NO.	DESCRIPTION	PART NO.
1	<b>XLR-IR Afocal Doubler</b> Doubles the distance of XLR-IR850 IR Illuminator beam. Comes complete with an thread adapter #174.	ANAF18XXLR
2	<b>Shuttered Eyeguard</b> Prevents light from being emitted by the Vulcan eyepiece.	ANEC000010
3	<b>Extended Rail Adapter #85</b> Dovetail Weaver Picatinny Rail Adapter Extends 7.5" to 11.5" Tactical Scope Mount.	ANAM000045
4	<b>Hard Shipping/Storage Case</b> A protective case used for shipping/storage of the Vulcan and its accessories.	ANH000004



## 2.5 KEY FEATURES

- Available in a variety of high-performing Gen 2+ and Gen 3 image intensifier tube options
- Shock protected, all-glass IR transmission multicoated optics
- Illuminated reticle with brightness adjustment
- Controls and adjustments are simple and easy to operate
- Equipped with wireless remote control
- Powered by a single AA or CR123A battery
- Automatic brightness control
- Manual gain control for the best possible image contrast in both high and low light conditions (MG models only)
- Bright light cut-off system
- Automatic shut-off system
- Bright light cut-off and low battery indication appear in the viewing area of the Vulcan
- Mounts to standard Picatinny/ Weaver rail with a quick release mount
- Detachable long-range XLR-IR850 illuminator
- Waterproof design
- Filled with dry nitrogen to prevent internal fogging
- MIL Standard compliant
- Limited two-year warranty

## 2.6 SYSTEM LIMITATIONS

The Vulcan requires some ambient light (moonlight, starlight, etc.) to operate. Factors that can reduce natural night light and negatively affect the efficiency and operation of the Vulcan include: rain, fog, sleet, snow, and smoke; passing cloud cover and objects that produce shadows; and low-contrast environments, such as snow-covered territory, sandy deserts, large bodies of water or grassy hills.

# OPERATING INSTRUCTIONS

## 3.1 INSTALLATION AND MOUNTING

### CAUTION:

In order to protect the intensifier tube, always keep the protective lens cap securely fitted over the lens if the sight is not in use or you are operating the device in daylight.

### 3.1.1 VULCAN BATTERY INSTALLATION

### CAUTION:

Before installing a battery, verify that the device is OFF.

To install the battery, do following (**refer to Figure 3-1**):

1. Unscrew the battery cap (A) and check the position of the battery adapter (B). See Figure 3-2 for the correct positioning of the threaded battery adapter, which changes depending on the battery being installed.
2. If necessary, use the special wrench to change the battery adapter's position in the cap.
3. Install the battery (C) into the battery compartment (D). Follow the battery symbol (E).
4. Replace the battery cap (A).

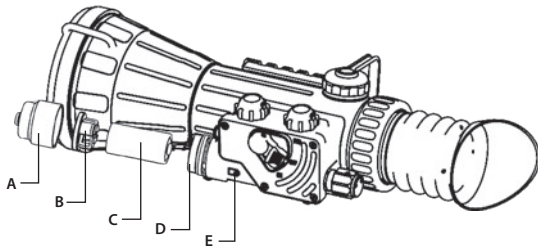
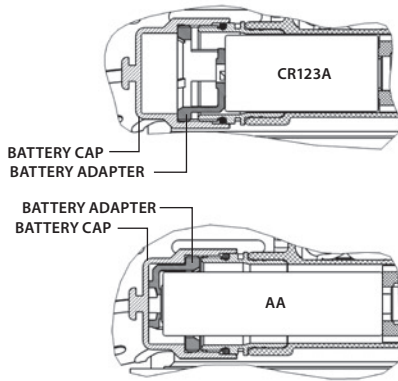

FIGURE 3-1. VULCAN BATTERY INSTALLATION



**FIGURE 3-2. BATTERY ADAPTER POSITIONS IN THE BATTERY CAP**

### 3.1.2 XLR-IR850 BATTERY INSTALLATION

**CAUTION:**

Ensure that the IR Illuminator is off before installing the battery.

1. Unscrew the battery cap (A).
2. Install the fully charged 18650 rechargeable battery (B) into the battery compartment. Align the polarity symbols on the battery with those on the cap face.
3. Replace the battery cap (A).

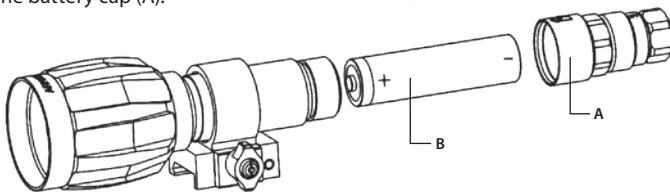

**FIGURE 3-3. XLR-IR850. BATTERY INSTALLATION**

### 3.1.3 INSTALLING THE VULCAN ON A WEAPON



**WARNING:**

When installing the equipment on a weapon, verify that the weapon is clear and that the safety is on before proceeding.

To install the Vulcan on a Picatinny/ Weaver rail, perform the following:

1. Unlock the clamping device of the Vulcan mount by pushing down on the lever holders (A, see Figure 3-4) and unlocking the levers (B).
2. Install the Vulcan on the Picatinny/ Weaver rail so that the stops (A, see Figure 3-5) slide into the transverse slots on the rail.
3. Affix the Vulcan to the rail by locking the levers (B, Figure 3-4).
4. Verify that the clamping device is firmly holding the Vulcan. If necessary, adjust the clamping device's lever-cam locks as detailed in Part 3.1.4 (Clamping Device Adjustment).

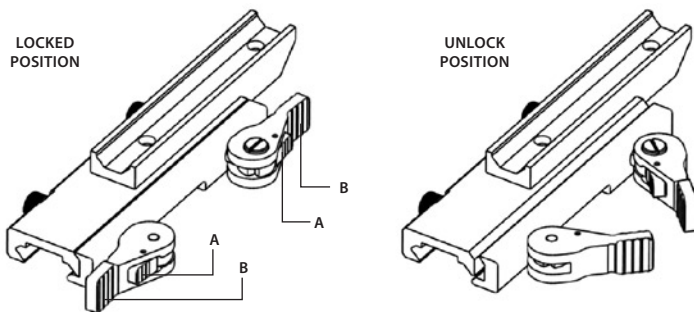

**FIGURE 3-4. VULCAN MOUNT. TOP VIEW**

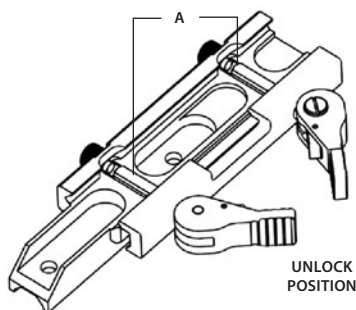
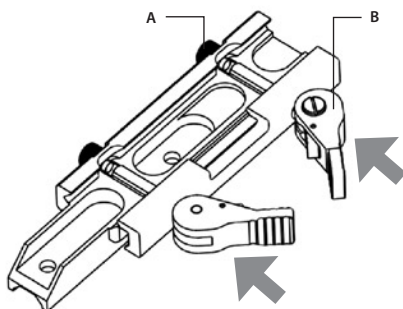

**FIGURE 3-5. VULCAN MOUNT. UNDERSIDE VIEW**

### 3.1.4 CLAMPING DEVICE ADJUSTMENT

To adjust the mount's clamping device, do the following:

1. Remove the Vulcan from the weapon.



**FIGURE 3-6. CLAMPING DEVICE ADJUSTMENT**

2. With the clamping device unlocked (as shown in Figure 3-6), push the cam (B) towards the arrow, which will cause the nut (A) to slide out of its hole.
3. To tighten/ loosen the clamping device, push down on the cam (B) and turn the nut (A) CW/ CCW respectively, in one-two increments (see note below). Much like when the cam (B) is released, backward-moving springs will cause the nut (A) to slide back into its hole.

**NOTE:**

The eight-sided nuts of the mount lever-cam locks will only fit into their holes if turned in one of the discrete positions, using increments equal to  $360^{\circ}/8$ .

4. Verify that the adjusted lever-cam lock securely holds the weapon mounting rail.
5. Repeat the procedure to adjust the clamping device's second lever-cam lock.

### 3.1.5 FASTENING AN ADVANCED WIRELESS REMOTE CONTROL TO A WEAPON

Using Velcro tape (A), fasten the Advanced Wireless Remote Control (B) (Figure 3-7) to your weapon in an easily accessible place (e.g., on the front of the rifle stock), preferably on the same side as the Vulcan's control compartment.

If your rifle has a Picatinny or Weaver rail on the front end, you can use the Picatinny adaptor for the Advanced Wireless Remote (C). Install the adaptor on the rail. Insert the remote control unit into the adaptor.

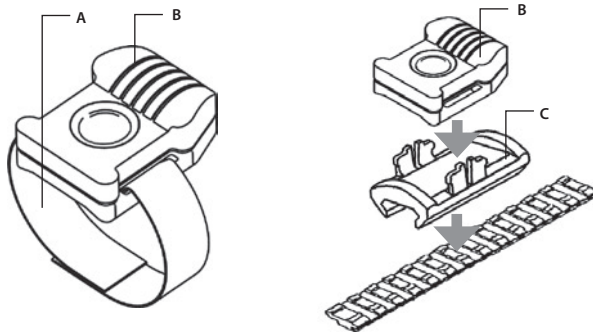

**FIGURE 3-7. ADVANCED WIRELESS REMOTE CONTROL**

### 3.1.6 INSTALLING THE XLR-IR850

The XLR-IR850 (Figure 3-8) is delivered ready-assembled with a dedicated mount, to be installed on the Weaver rail of the Vulcan or weapon. The mount clamp (A) has a spherical hinge that allows the XLR-IR850 to tilt.

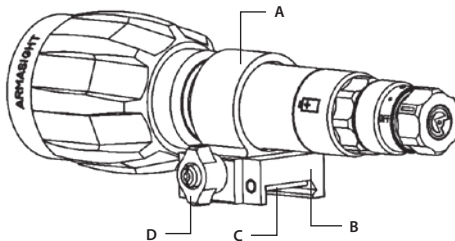

**FIGURE 3-8. IR-850 ILLUMINATOR**

Mount the XLR-IR850 on the Weaver rail as follows:

1. Loosen the nut (D). Install the mount (B) on the Weaver rail so that the stop (C) slides into one of the transverse slots of the rail.
2. Tighten the nut (D) using a screwdriver.

## 3.2 CONTROLS AND INDICATORS

### CAUTION:

DO NOT force the equipment controls past their stopping points.

### 3.2.1 VULCAN CONTROLS AND INDICATORS

The Vulcan controls are shown in Figure 3-9.

The Vulcan controls and indicators are defined in Table 3-1. The ITEM NO. column indicates the number used to identify items in Figure 3-9.

The Vulcan controls described elsewhere in this manual (levers and nuts of the clamping device) are not included in this section.

**TABLE 3-1. VULCAN CONTROLS AND INDICATORS**

ITEM NO.	CONTROL/INDICATOR	FUNCTION
1	Pivoted Shutter	Closes/ opens the photoreceiver when placed in the highest/ lowest position.
2	Turn Switch	Switches the Vulcan on, when turned from OFF to ON. <b>NOTE:</b> Both the ON and STB positions can only be used if the switch is unlocked. Unlock the switch by pushing down on the spring-loaded stop (3, Figure 3-9) before turning. Switches the device to standby mode, when turned from OFF to STB position (see note above). Switches the Vulcan off, when turned from ON/ STB to OFF.
3	Spring-loaded Stop	Locks the turn switch in the OFF position.
4	Eyepiece Ring	Adjusts the diopter. Adjusts for the sharpest view of the scene.
5	Gain Control Knob (only MG models)	Adjusts the brightness of the image.
6	Reticle Brightness Adjustment Knob	Adjusts the brightness of the red reticle in the Vulcan's field of view.
7	Elevation Adjustment Turret (closed with a cap)	Adjusts the riflescope's boresight.
8	Windage Adjustment Turret (not shown)	Adjusts the riflescope's boresight.
-	Remote Control Button	Activates/ deactivates the Vulcan in standby when pressed/ released.
-	Low Battery Indicator	FLASHING RETICLE in viewing area indicates a low battery.

The Armasight Vulcan Mil-dot reticle is a reliable means of determining distances to targets, establishing leads for moving targets, and for alternate aiming points for windage and elevation holds.

Dots are spaced in one mil (milliradian) increments on the crosshair. A distance to target can be calculated using the mil formula, that is based on the size of the object being targeted.

Look through the scope, and bracket the object between dots.

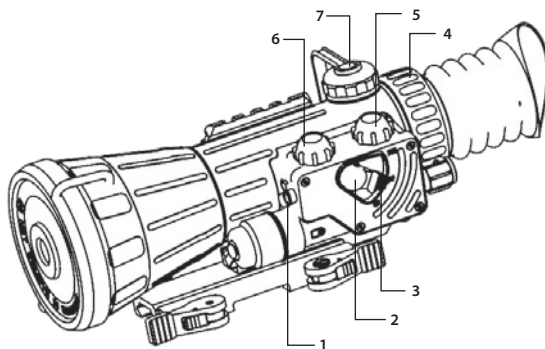

**FIGURE 3-9. VULCAN CONTROLS**

The space between dot centers subtends one milliradian (mil). One mil. subtends 3.6 inches at 100 yards or 36 inches at 1,000 yards. To use this system effectively you must know the size of the target.

By measuring the height or width of a known (or approximately known target size) in mil-radians using the reticles, the target distance can be calculated as follows.

R = range in meters, H = target size in meters, M = mil-radians of the image size:  **$R = 1000 * H / M$**

Military shooters are trained to know that the common male torso is 39 inches from crotch to top of head. This is very close to exactly one meter.

This formula then becomes  **$R = 1000 / M$**  for a one meter target size.

All of the following formulae are equivalent to the one above for estimating range.

R = range in meters, H = target size in inches, M = mil-radians of the image:  **$R = 25.4 * H / M$**

R = range in yards, H = target size in inches, M = mil-radians of the image:  **$R = 27.78 * H / M$**

R = range in yards, H = target size in feet, M = mil-radians of the image:  **$R=333.3 * H / M$**

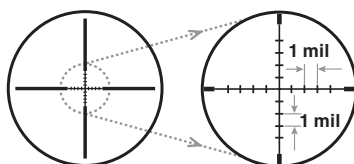

**FIGURE 3-10. MIL-DOT RETICLE**

### 3.2.2 XLR-IR850 CONTROLS

The XLR-IR850 controls are shown in Figure 3-11 and defined in Table 3-2. The ITEM NO. column indicates the number used to identify items in Figure 3-11.

**TABLE 3-2. XLR-IR850 CONTROLS**

ITEM NO.	CONTROL	FUNCTION
1	Power Switch	Switches the IR illuminator on/off and adjusts for radiated power. Four ON positions are located between the two OFF positions, and are each marked with a different-sized spot. The larger the spot, the greater the radiated power.
2	Lens Focus Ring	Adjusts for IR beam divergence. Adjustment range is covered within approximately one turn of the lens.

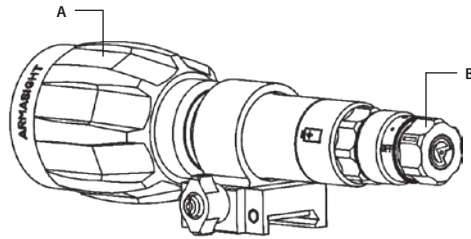

**FIGURE 3-11. XLR-IR850 CONTROLS**

## 3.3 OPERATING PROCEDURES

Operating procedures should be performed in nighttime conditions only.



### **WARNING:**

Always make sure your firearm is unloaded before you place the scope on the firearm. Reconfirm that the chamber is empty if you stop the procedure then resume later. Safe handling rules should be followed at all times.

### **CAUTION:**

The use of Vulcan in brightly lit conditions may damage the image intensifier.

### **CAUTION:**

Pay close attention to the caution notice on the objective lens cap: "Do not remove in daylight."

### 3.3.1 BORESIGHT ADJUSTMENT PROCEDURE

#### **NOTE:**

Before adjusting the Vulcan boresight for the first time, install the device and fire approximately 10 shots, in order to stabilize the adjustment mechanisms under applied shocks.

The vertical and horizontal adjustments for the Armasight Vulcan can be regulated by rotating the elevation and windage adjustment turrets. Each click represents  $\frac{3}{5}$  inch at a 100 yard distance. Once the turret comes to a complete stop, avoid forcing it any further, as damage to the mechanism may occur. To adjust the boresight:

1. Locate a target at the fire adjustment range (100 yd).
2. Take aim at the center of the target using the weapon's iron sight; secure the weapon in the aiming rest.
3. Unscrew the caps from the adjustment turrets.
4. Turn the switch to the ON position.
5. Look into the eyepiece. Using a screwdriver (or empty cartridge case), turn the adjustment turrets until the reticle moves into the center of the target.



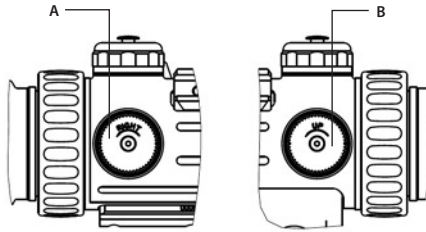

**FIGURE 3-12. WINDAGE AND ELEVATION ADJUSTMENT TURRETS**

**NOTE:**

To shift the aiming dot to the right, turn the windage adjustment screw CCW. To shift it to the left, turn the screw CW.

To shift the aiming dot down, turn the elevation adjustment screw CCW. To shift it up, turn the screw CW.

6. Fire a series of shots.
7. Work out the values of the elevation and windage corrections required to compensate for the measured deviation of the mean point of impact (MPI) from the center of the target. The minimum correction value of 17 SOA for Vulcan 4.5X (1/3 inch at a distance of 100 yards or 0.85cm at a distance of 100m), 12 SOA for Vulcan 6X (1/5 inch at a distance of 100 yards or 0.6cm at a distance of 100m), and 9 for Vulcan 8X (1/6 inch at a distance of 100 yards or 0.45cm at a distance of 100m) corresponds to one click of the adjustment mechanisms.
8. Adjust the equipment boresight by turning the adjustment screws and counting out a definite number of clicks (or reading the scales).

**NOTE:**

To shift the MPI to the right, turn the windage adjustment screw CW. To shift the MPI to the left, turn the screw CCW.

To shift the MPI down, turn the elevation adjustment screw CW. To shift the MPI up, turn the screw CCW.

9. To check the equipment's boresight, take aim at the center of the target and fire a series of shots.
10. After completing the boresight adjustment procedure, turn the device OFF and replace the caps on the adjustment turrets.

**3.3.2 VULCAN OPERATING PROCEDURES**

1. Verify that the battery is installed as required.
2. Perform a visual estimation of the illumination level in the viewing area, using the reference data presented in Appendix A. You can begin operating the Vulcan if the illumination level is less than 1 lux.
3. Remove the objective lens cap and place it over the lens' housing.

**CAUTION:**

Before removing the objective lens cap, verify that the photoreceiver is open.

4. Verify that there are no bright light sources in the Vulcan's field of view. Turn the device ON. After a slight delay, a green glow will appear in the day scope's output lens.

**CAUTION:**

Avoid exposing the device to bright light sources such as firelight, headlights, searchlights, etc., as these can damage the Vulcan.

5. To operate the Vulcan in short-time activation mode, turn the switch to the STB position. To activate the Vulcan, press and hold the remote control button. Release the remote control button to deactivate the Vulcan.
6. Observe the scene and adjust the focus. To focus the Vulcan, turn the diopter ring clockwise until it stops. Then, while looking through the eyepiece, aim the sight towards an object in the distance and begin slowly rotating the diopter ring in a counterclockwise direction until the image becomes sharp and clear.

**NOTE:**

If you are operating your Vulcan in daylight, be sure that the protective lens cover is securely fitted over the objective lens before you begin adjusting the diopter.

7. Adjust the image contrast by rotating the Vulcan's gain control knob.
8. Adjust the brightness of reticle by rotating the reticle brightness control knob.

**CAUTION:**

Do not leave the Vulcan activated if it is not being used.

**NOTE:**

If the automatic shut-off system automatically turns off the device when it is used you need turn the operation switch to OFF position and then back to ON position for continuing the operation.

### 3.3.3 OPERATING XLR-IR850

Use the XLR-IR850 in poor light conditions or complete darkness.

**CAUTION:**

When operating the device in extremely dark conditions, the light from the unit's IR illuminator will be invisible to the naked eye. However, the light can be detected by other NVDs.

**NOTE:**

Do not leave the XLR-IR850 activated when the device is not in use.

1. After examining a scene with the Vulcan, turn on the XLR-IR850.
2. To change the radiated power level, turn the power switch to one of the spots in between the two OFF positions.
3. To adjust IR beam divergence, turn the lens.
4. To adjust the IR spot position in the field of view, loosen the clamp screw and tilt the XLR-IR850 as required in the spherical clamp hinge. Tighten the screw using a 2.5mm hex key.

The XLR-IR850 can be used as hand-held long-range IR illuminator with optional Afocal Doubler. Attach the magnifying lens to the XLR-IR850 as follows (refer to Figure 3-13):

1. Screw the Afocal Doubler (A) into the threading adapter (B).
2. Screw the Afocal Doubler with adapter into the threading of the XLR-IR850 objective lens (C) housing. Be careful not to over-tighten the lens.

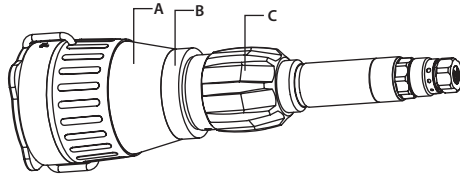

**FIGURE 3-13. XLR-IR850 ILLUMINATOR WITH AFOCAL DOUBLER**

**NOTE:**

The caution notice **DO NOT REMOVE IN DAYLIGHT** on the front lens cap of this universal magnifying lens is not applicable when using it on the XLR-IR850.

### 3.3.4 OPERATING IN CHANGING LIGHT CONDITIONS

If a mission must be carried out in changing light conditions, you can deactivate the bright light protection system of the Vulcan. To shut down the protection system, close the photoreceiver by flipping up the pivoted shutter.

**CAUTION:**

After your mission is complete, open the photoreceiver by flipping the pivoted shutter down.

### 3.3.5 SHUT-DOWN

Shut-down the Vulcan as follows:

1. Turn the device OFF. The green glow will disappear.
2. Place the cap over the objective lens.
3. Remove the Vulcan from the weapon.
4. Remove the light suppressor from the output lens.
5. Replace the cap on the output lens.
6. Remove the XLR-IR850 from the Vulcan Weaver rail.
7. Remove the battery.

**CAUTION:**

Do not store the equipment with the battery still installed.

**CAUTION:**

To avoid deformation or damage, remove the light suppressor from the Vulcan.

8. Ensure that the Vulcan and any accessories are clean and dry before placing them into the storage case.
9. Place the Vulcan and any accessories into the storage case.
10. Store the Vulcan and accessories in the appropriate locations in the case and close the cover.

# PREVENTIVE MAINTENANCE AND TROUBLESHOOTING

## 4.1 PREVENTIVE MAINTENANCE CHECKS AND SERVICES

### 4.1.1 PREVENTIVE MAINTENANCE CHECKS AND SERVICES (PMCS)

Table 4-1: Preventive Maintenance Checks and Services have been provided so that you can keep your equipment operable and in good condition.

Perform all functional tests in the order listed in Table 4-1.

Operating Procedures are detailed in Chapter 3.

#### A. Cautions

Always observe any CAUTIONS that appear in the table.

#### B. Explanation of Table Entries

**SEQ NO. column.** Sequence numbers are for reference and appear in the order required to perform checks and services.

**LOCATION OF ITEM TO CHECK/ SERVICE column.** Indicates the location and the item to be checked or serviced.

**PROCEDURE column.** Details the checking/ servicing procedure.

**NOT FULLY MISSION CAPABLE IF ... column.** Indicates what faults will prevent your equipment from operating successfully.

**TABLE 4-1. PREVENTIVE MAINTENANCE CHECKS AND SERVICES**

SEQ NO.	LOCATION OF ITEM TO CHECK/ SERVICE	PROCEDURE	NOT FULLY MISSION CAPABLE IF ...
PRE-OPERATION CHECKS			
1	Completeness	Open the carrying case and inventory items by comparing them with the data specified in this manual.	Items are missing.
2	Body	Inspect for cracks or damage. Scratches and gouges are OK if operation is not affected. Inspect for missing parts (purge screw, knobs).	Cracked or damaged. Purge screw or knob is missing.
3	Objective Lens Cap	Inspect for cracked, torn, or missing lens cap.	Cap is torn or cut. Cap is not secured to the housing of the lens.

**TABLE 4-1. CONTINUED**

<b>SEQ NO.</b>	<b>LOCATION OF ITEM TO CHECK/ SERVICE</b>	<b>PROCEDURE</b>	<b>NOT FULLY MISSION CAPABLE IF ...</b>
4	Eyecup	Inspect for dirt and dust. Inspect for cracked, torn, bent, broken, or improperly fitting eyecup.	Cup is torn or cut.
5	Battery Compartment/ Cap / Battery Adapter	Check to make sure the battery adapter is present. Check for corrosion, cap damage or retainer breaks. Check O-ring for cuts or damage.	Retainer is broken. Cap, O-ring or battery adapter is damaged or missing.
6	Switch	Check for operation (without battery).	Switch is inoperative.
7	Lenses	Inspect for cleanliness, scratches, chips or cracks. Clean as required.	Chipped or cracked. Scratches hinder vision through the Vulcan.
8	Photoreceiver	Inspect for cleanliness, scratches. Clean as required.	Photoreceiver is damaged.
9	Eyepiece Ring	Check to ensure there is free rotation through full range of travel.	Ring is inoperative.
10	Focus Knob	Check to ensure there is free rotation through full range of travel.	Knob is inoperative. Knob is missing.
11	Gain Control Knob	Check to ensure there is free rotation through full range of travel.	Knob is inoperative. Knob is missing
12	Reticle Brightness Adjustment Knob	Check to ensure there is free rotation through full range of travel.	Knob is inoperative. Knob is missing
13	Advanced Wireless Remote Control	Check for damage. Check Velcro tape for wear.	Damaged. Unit or tape is missing.
14	Mount	Inspect for damage or corrosion, and for missing parts. Check for proper operation.	Damaged. Some parts are missing. Clamping device is inoperative.
15	XLR-IR850 Body, Mount	Inspect for damage and missing parts. Check for proper operation.	Damaged. Missing parts. Mount is inoperative.
16	XLR-IR850 Battery Cap, Power Switch	Check O-ring for damage. Check for proper operation.	O-ring is damaged or missing. Switch is inoperative.
17	XLR-IR850 Lens	Inspect for cleanliness, scratches, chips or cracks. Clean as required. Check to ensure there is free rotation through the full range of travel (1 turn).	Lens is chipped or cracked. Lens is sticking or too loose when turned.

**OPERATIONAL CHECKS**

**CAUTION:**

The objective lens cap has an optical filter, which allows operational testing of the Vulcan in daylight. Activate the Vulcan in daylight **only** with the objective lens cap on or in dark conditions.

**NOTE:**

Daylight checks are described below.

18	Vulcan Switch	Insert the battery. Remove the output lens cap. Close the photoreceiver by flipping up the pivotal shutter. Turn the switch to ON. Look for green glow (after a slight delay) in viewing area.	No green glow.
		Open photoreceiver by flipping the pivotal shutter down. Look through the output lens and wait about 20 seconds for the green glow to disappear.	Green glow is present, red glow is absent.
19	Remote Control	Put the unit in STB mode. Press and hold the remote control button. Look for the green glow in output lens. Release the button. Turn the device OFF.	Green glow is absent.
20	Eyepiece Ring	Turn the device ON. Rotate the eyepiece ring to ensure it adjusts the diopter.	Ring does not adjust the diopter.
21	Focus Knob	Turn to the device ON. Rotate the knob to ensure it adjusts for focus.	Knob does not adjust for focus.
22	Gain Control Knob (only MG models)	Rotate the gain control knob to ensure it changes the screen's brightness.	Knob does not adjust the screen's brightness.
23	Reticle Brightness Adjustment Knob	Rotate the reticle brightness adjustment knob to ensure it changes the reticles brightness.	Knob does not adjust the reticles brightness.
24	Viewed Image	Check for flickering, flashing, bright spots, edge glow, shading, or excessive fixed-pattern noise (honeycomb).	Excessive cosmetic defects or fixed pattern noise is present.

TABLE 4-1. CONTINUED

SEQ NO.	LOCATION OF ITEM TO CHECK/ SERVICE	PROCEDURE	NOT FULLY MISSION CAPABLE IF ...
25	XLR-IR850	Insert the battery. Mount the IR850 onto the Vulcan. Turn on the XLR-IR850. Direct the radiated beam at a wall from a distance of about 5m. Look through the Vulcan. A square of light should appear on the wall.	No light appears on the wall.
POST-CHECK PROCEDURES			
26		Turn off the XLR-IR850 and Vulcan. Replace the protective cap over the Vulcan output lens. Remove the battery. Return the unit and all accessories to the storage case.	

## 4.2 OPERATOR TROUBLESHOOTING

The purpose of troubleshooting is to identify the most commonly occurring equipment malfunctions, their probable causes, and the corrective actions required to fix them.

Table 4-2 lists common malfunctions that may occur during the operation or maintenance of the Vulcan. Perform the tests, inspections, and corrective actions in the order listed in the table

**This table does not list all of the malfunctions that may occur with your device, or all of the tests and corrective actions that may be necessary.** If you experience an equipment malfunction that is not listed, or is not fixed by the corrective actions listed in the table, please contact Armasight's Customer Service center.

TABLE 4-2. OPERATOR TROUBLESHOOTING

MALFUNCTION	PROBABLE CAUSE/ TEST/INSPECTION	CORRECTIVE ACTION
Equipment fails to activate.	Battery is missing or improperly installed.	Insert battery or install it correctly.
	Battery is dead.	Replace the battery.
	Battery surfaces or contacts are dirty or corroded.	Clean the contact surfaces with a pencil eraser and/ or alcohol and cotton swabs.
	Advanced Wireless Remote Control is damaged.	Please contact Customer Support.
	Remote control battery is dead.	Replace the battery as per Part 4.3.3.2.
Poor image quality.	Defective image intensifier.	Please contact Customer Support.
	Check focus.	Refocus.
	Objective and output lenses are dirty.	Thoroughly clean the surfaces of each lens.
Diopter adjustment cannot be performed	Damaged optical components.	Please contact Customer Support.
	Check to see if the diopter adjustment ring is deformed or broken.	If the diopter adjustment ring is damaged, contact your service center.
Vulcan affects boresight after installation or during firing.	Alignment broken.	Please contact Customer Support.
Hindered rotation of the battery cap.	Dirty cap thread.	Clean the thread.
	Damaged cap thread.	Please contact Customer Support.
Battery adapter difficult to remove.	Check for damaged battery adapter and battery cap.	If damaged please contact Customer Support.
Light is visible through the eyecup.	Check the exit pupil distance value.	Press the eyecup to your face.
	Check the eyepiece resilience.	If the eyecup is defective, contact Customer Support.
IR850 fails to activate.	Battery is missing or improperly installed.	Insert battery or install it correctly.
	Battery is dead.	Replace the battery.
	IR850 damaged.	Please contact Customer Support.

## 4.3 IDENTIFICATION OF OPERATIONAL DEFECTS

### 4.3.1 OPERATIONAL DEFECTS

Operational defects relate to the reliability of the intensifier, and are an indication of instability. If identified, the user will need to return the Vulcan immediately. Operational defects include shading, edge glow, flashing, flickering, and intermittent operation.

#### A. Shading

If shading is persistent, you will not be able to see a fully circular image (Figure 4-1). Shading is a very dark, high-contrast area with a distinct line of demarcation present, and you cannot see an image through it. Shading always begins on the edge, and will eventually migrate inward until it spans across the entire image area. If you notice shading with your device, please contact Customer Support.

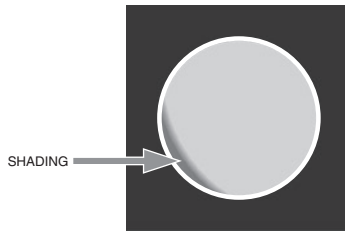

FIGURE 4-1. SHADING

#### NOTE:

Verify that any shading is not the result of improper eye-relief adjustment.

#### B. Edge Glow

Edge glow is a bright area (it sometimes appears to be coloring) in the outer portion of the viewing area (see Figure 4-2). To check for edge glow, block out all light from the device by cupping a hand over the lens. If the image tube is displaying edge glow, the bright area will still show up; if edge glow occurs, please contact Customer Support.

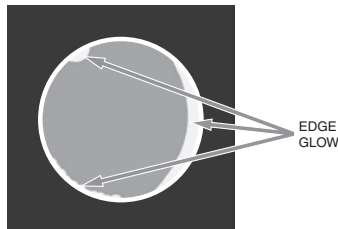

FIGURE 4-2. EDGE GLOW

#### C. Flashing, Flickering, or Intermittent Operation

The image may appear to flicker or flash. If there is more than a single flicker, check for a loose battery adapter or a weak battery. If flickering continues, please contact Customer Support.

### 4.3.2 COSMETIC BLEMISHES

Cosmetic blemishes are usually the result of manufacturing imperfections. They do not affect the reliability of the image intensifier, and are not normally cause for returning the Vulcan. However, some types of cosmetic blemishes can worsen over time and interfere with the user's ability to properly oper-

ate the device during missions. If you believe a cosmetic blemish is cause for returning the device, record the specific nature of the problem on the maintenance forms and use the clock method to identify the position of the blemish and its approximate distance from the center (e.g., 5:00 toward the outside, 2:30 near the center, or 1:00 midway).

The following are examples of cosmetic blemishes:

### A. Bright Spots

A bright spot is a small, non-uniform bright area that may flicker or appear constant (Figure 4-3).

Not all bright spots make the Vulcan returnable. Cup your hand over the lens to block out all light. If the bright spot remains, please contact Customer Support.

Bright spots usually go away when all light is blocked out. Verify that any bright spots are not simply the result of bright light in the area you are observing. Bright spots are acceptable if they do not interfere with the user's ability to view the scene or perform missions.

### B. Emission points

Emission points are steady or fluctuating pinpoint of bright light in the image area that do not go away when all external light is blocked from the objective lens (Figure 4-3). The position of an emission point within the image area does not move. Not all emission points are cause to return the Vulcan. Verify that emission points are not simply light sources present in the scene you are observing. Emission points are acceptable if they do not interfere with the user's ability to perform missions.

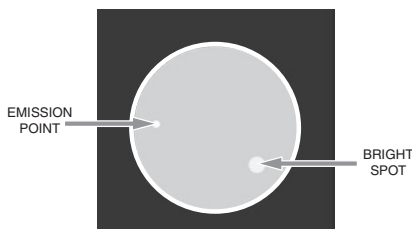

FIGURE 4-3. EMISSION POINTS AND BRIGHT SPOTS

### C. Black Spots

Black spots are cosmetic blemishes in the image intensifier or debris between the lenses. Black spots are acceptable as long as they do not interfere with the user's ability to observe the scene. No action is required if this condition is present, unless the spots interfere with the operator's ability to perform missions.

### D. Fixed-pattern Noise

Fixed-pattern noise is usually a cosmetic blemish characterized by a faint hexagonal (honeycomb) pattern that appears throughout the viewing area. This typically occurs in excessively lit environments or when viewing very bright lights (see Figure 4-4). This pattern can be seen in every image intensifier if the level of light is high enough. This condition is acceptable as long as the pattern does not interfere with the user's ability to view an image or interfere with their ability to perform missions.

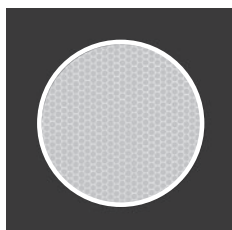

FIGURE 4-4. FIXED-PATTERN NOISE



## E. Chicken Wire

Chicken wire is an irregular pattern of dark thin lines that can appear in the field of view, either throughout the image area or in sections of the image area (see Figure 4-5). In the worst-case scenario, these lines will form hexagonal or square, wave-shaped lines. No action is required if this condition is present, unless it interferes with the user's ability to view the image or their ability to perform missions.

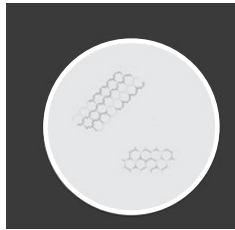

FIGURE 4-5. CHICKEN WIRE

## 4.4 MAINTENANCE

### 4.4.1 GENERAL

The section regarding Vulcan operator maintenance consists of operational tests, inspections for unit serviceability, cleaning and mounting procedures, and replacement instructions for a limited number of parts. Maintenance instructions covered elsewhere in this manual (PMCS, troubleshooting, etc.) are not repeated in this section.

#### CAUTION:

The Vulcan is a precision electron-optical instrument, and must be handled carefully at all times to prevent damage to the device's body and mechanisms.

### 4.4.2 CLEANING PROCEDURES

#### CAUTION:

Thoroughly dry each item before placing them into the storage case.

Clean the Vulcan as follows:

1. Gently brush off any dirt from the unit's body using a clean, soft cloth.
2. Moisten the cloth with fresh water and gently wipe external surfaces (**except** for glass surfaces).
3. Dry any wet surfaces (**except** for glass surfaces) with another clean, soft, dry cloth.
4. Using a lens brush, carefully remove all loose dirt from the glass surfaces.
5. Slightly dampen a cotton swab with ethanol. Gently and slowly wipe the lenses (including the photoreceiver and the pivotal focusing lens). Without touching the lens holders, clean the glass surfaces in circular movements, beginning in the center and moving out towards the edge. Change the cotton swab after each circular stroke. Repeat until the glass surfaces are clean.
6. Clean the battery contact surfaces and contact springs with a pencil eraser and/ or alcohol-dampened cotton swabs.

Clean optional devices with a soft brush (cloth), soap, and water as required.

### 4.4.3 BATTERY REMOVAL AND REPLACEMENT

Refer to Part 3.1.1 for Vulcan and XLR-IR850 battery installation procedures.

Replace the remote control battery as follows:

1. Using a screwdriver, unscrew the four screws (A, Figure 4-6) that affix the cover to the bottom of the unit. Remove the cover.
2. Replace the battery with new one (CR2032, 3V). Align the polarity (plus and minus) symbols on the battery with those on the battery compartment.
3. Replace the cover and retighten the screws (A).

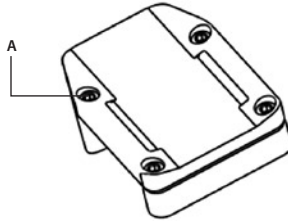

**FIGURE 4-6. ADVANCED WIRELESS REMOTE CONTROL. BATTERY INSTALLATION**

## 4.5 RETURN INSTRUCTIONS

For service, repair or replacement, please email [service@armasight.com](mailto:service@armasight.com).

To assist the Service Representative (SR) with determining whether or not an item is repairable, please provide the following information:

1. Serial Number of the defective item. This is engraved on the body of the device.
2. Thorough description of the malfunction, defect or damage.
3. An explanation of how the malfunction, defect or damage occurred, if known.

If the SR determines that the item is under warranty or should be returned for repair, a Return Material Authorization number (RMA#) will be provided. RMA can be obtained via e-mail to [service@armasight.com](mailto:service@armasight.com), via phone by calling Armasight Customer Service at (888) 959-2259 Ext. 2, or via fax at (888) 959-2260.

When returning the Vulcan for service or repair, the following procedures should be done to prevent any additional damage:

1. Verify that the Vulcan is free of all contaminants, such as dirt or any other foreign material.
2. Remove the battery.
3. Place the cap over the objective lens.
4. Screw the cap onto the output lens.
5. Place the Vulcan and its accessories into the shipping case. Place the Vulcan and a copy of the test report (or detailed description of the failure) in a suitable packing/ shipping container. Mark the package with the RMA#. Ship using a fast, traceable service. Shipping must be prepaid by the Customer.

## A. ESTIMATION OF AMBIENT ILLUMINATION LEVEL

Table A-1 lists some common natural light conditions and their corresponding representative illumination values.

**TABLE A-1. STANDARD NATURAL LIGHT CONDITIONS AND ILLUMINATION VALUES**

STANDARD NATURAL LIGHT CONDITIONS	ILLUMINATION VALUE, LUX
Quarter moon	0.05
Full moon	0.30
Late twilight sky	1.00
Twilight sky	10.00
Overcast sky in the daytime	500.00

## B. LIST OF SPARE PARTS

The parts authorized in the below list of spare parts are required for operator maintenance. This list includes parts that must be removed in order to replace authorized parts.

The ITEM NO. Column indicates the number used to identify items in Figure B-1.

The PART NO. Column indicates the primary number used by the manufacturer to identify an item; this number controls the design and characteristics of the item by means of its engineering, specifications, standards, and inspection requirements.

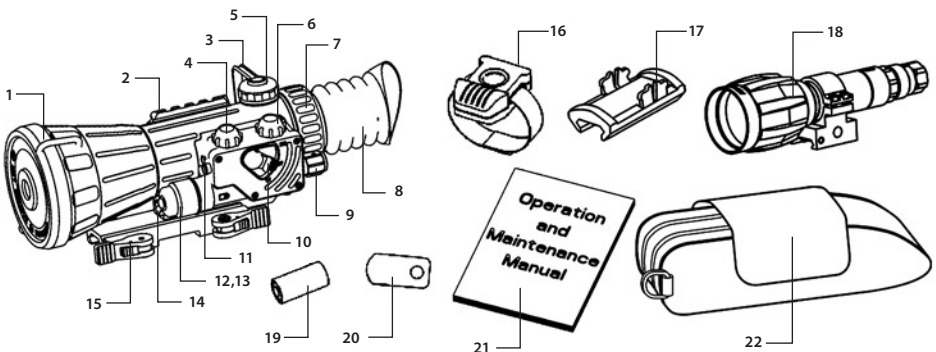

**FIGURE B-1. VULCAN SPARE PARTS**

**TABLE B-1. VULCAN LIST OF SPARE PARTS**

ITEM NO.	DESCRIPTION	PART NO.
1	Objective Lens Cap	VLCOLC
2	Weaver Rail	VLCWR
3	Turret Cap Retainer	VLCTCR
4	Reticle Brightness Adjustment Knob	VLCKNB
5	Turret Cap	VLCTC
6	Gain Control Knob	VLCKNB
7	Eyepiece Assembly	VLCEPA
8	Eyepiece Cup	VLCEPC
9	Focus Knob	VLCFKB
10	Turn Switch with Spring-loaded Stop	VLCTS
11	Pivoted Shutter	VLCPS
12	Battery Cap	VLCBC
13	Battery Adapter	VLCBA
14	Battery Cap Retainer	VLCBCR
15	Double Lever-Lock Quick Release Picatinny Mount	VLCQRM
16	Advanced Wireless Remote Control	ANWR000001
17	Picatinny Adapter for Advanced Wireless Remote Control	ANRA000002
18	XLR-IR850 Detachable Long Range Infrared Illuminator	IAIR850IR000003
19	CR123A Lithium Battery	CR123A
20	Special Wrench	VLCSW
21	Operation and Maintenance Manual	VLCOMM
22	Carrying Case	VLCC

## C. PRODUCT WARRANTY REGISTRATION CARD

In order to validate the warranty on your product, Armasight must receive a completed Product Warranty Registration Card for each unit, or the user must complete warranty registration on our website ([www.armsight.com](http://www.armsight.com)). Please complete the included form and immediately mail it to our Service Center:

Armasight Inc.

815 Dubuque Avenue

South San Francisco, CA 94080

USA

## ARMASIGHT PRODUCT WARRANTY REGISTRATION CARD

### PRODUCT INFORMATION

Product Name \_\_\_\_\_ Purchased From \_\_\_\_\_

Purchase Date \_\_\_\_\_ Product Serial # \_\_\_\_\_

### CUSTOMER INFORMATION

Name \_\_\_\_\_

Address \_\_\_\_\_

City \_\_\_\_\_ Country \_\_\_\_\_ Zip \_\_\_\_\_

Day Phone # \_\_\_\_\_ Home Phone # \_\_\_\_\_

E-mail address \_\_\_\_\_

.....  
Customer Signature Required







Armasight Inc.

815 Dubuque Avenue  
South San Francisco  
CA 94080, USA

Phone: (888)959-2259

Fax: (888)959-2260

Intl Phone/Fax: (650)492-7755

[info@armasight.com](mailto:info@armasight.com)

**CAUTION:**

**This product contains natural rubber latex which may cause allergic reactions!** The FDA has reported an increase in the number of deaths that are associated with an apparent sensitivity to natural latex proteins. If you are allergic to latex, it is a good idea to learn which products contain it and strictly avoid exposure to those products.

[www.armasight.com](http://www.armasight.com)