



# LEUPOLD

## Leupold® DeltaPoint® Pro Reflex Sight

### Mounting & Operation Instructions

## Operating Instructions

For optimum performance and to prevent damage to this precision instrument, carefully follow all instructions.

### Features

- DiamondCoat™, scratch resistant aspheric lens for brightness, and resolution
- Motion Sensor Technology (MST™)
- Extremely durable, ultra light aluminum housing
- Small size and lightweight
- Unlimited eye relief
- For handguns, rifles and shotguns
- Wide field-of-view
- Blackened lens edges
- Waterproof to 33ft.

### Specifications

- Magnification: 1.0x
- Sight window: 25.7mm x 17.5mm; 1.01" x 0.68"
- Elevation adjustment range: 60 MOA
- Windage adjustment range: 60 MOA
- 40 MOA per revolution of adjustment (1 MOA per click)
- Subtension of the aiming point : 2.5 MOA Dot, 7.5 MOA inscribed Delta
- Operating Temperature Range: -20°F to +120°F (-29°C to +49°C)
- Storage Temperature Range: -40°F to +160°F (-40°C to +71°C)
- Power Supply: 3V with one CR 2032 Lithium battery
- Dimensions: (LxWxH) 1.82" x 1.31" x 1.30" (46.1mm x 33.2mm x 33.0mm)
- Weight (with battery installed): 1.9oz. (53.8g)

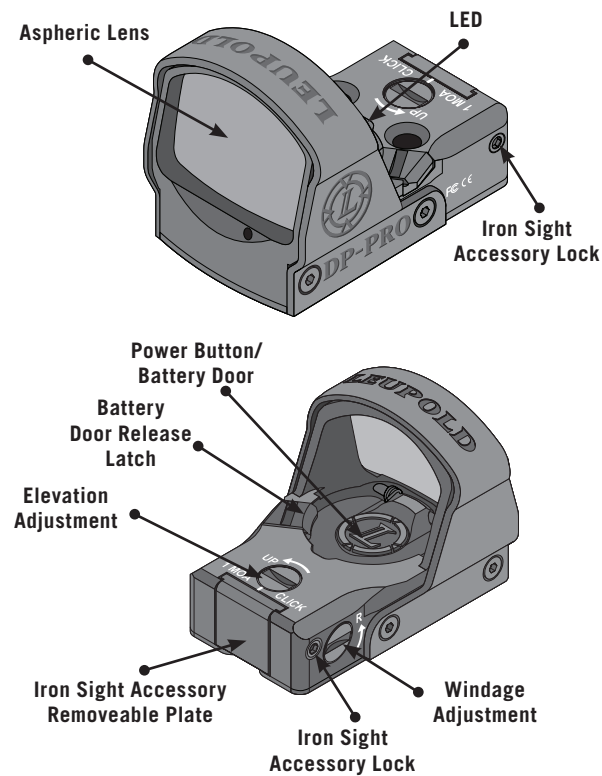

### Package Contents

- DeltaPoint Pro Reflex Sight, Delta (SKU 119687) or
- DeltaPoint Pro Reflex Sight, 2.5 MOA Dot (SKU 119688)
- (1) 3V Lithium battery (CR 2032)
- (1) Protective cover
- (2) M4x.7x15.8mm Torx® head screws for installing the sight on the mounting plate
- (1) Torx® T-15 wrench
- (1) 1/16 Hex wrench
- Operating Instructions

### Accessories (sold separately)

- Cross-Slot Mount (SKU 120056)
- Rear Iron Sight (SKU 120058)
- Cross-Slot Riser (SKU 120059)
- All Pistol Mounts Kit (SKU 120057)



### Cautions & Warnings:

Check to ensure that the magazine of the firearm has been removed or emptied, that the action is open, and that there is not a round in the chamber. Only after double checking the firearm, verifying it is empty and safe, should you proceed with the installation of the DeltaPoint Pro. Do not look directly into the sun, light arcs or other high-intensity light sources. Keep away from children.

### Battery Installation

The unit operates with one commercially available 3V Lithium battery (CR 2032) only. Open the battery cover by pulling back the battery door release latch. Insert the battery so the positive side (+) is facing up and close the battery cover. Push the battery door release latch into place. Verify the white witness mark is fully covered by the latch. Keep the contact surface clean of dirt and corrosion, cleaning with alcohol if necessary.

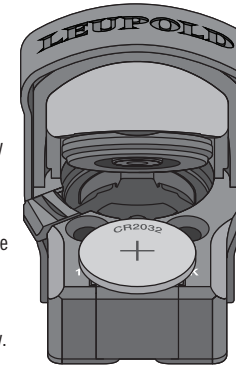

### Illumination Operation

DeltaPoint Pro is equipped with eight illumination intensities. To activate the DeltaPoint Pro press and release the power button. Cycling through the illumination intensities is done by repeatedly pressing and releasing the power button. When the highest or lowest setting is reached, the LED will flash 5 times. To change the direction of adjustment, i.e., change from increasing intensity to decreasing intensity, press and hold the power button for 2 seconds and immediately release the button. Then continue pressing and releasing to change intensity.

To power the DeltaPoint Pro off, press and hold the power button for approximately 3 seconds, or until the LED turns off. When reactivated, the unit will return to the last known setting.

### Low Battery Indicator

The DeltaPoint Pro has a unique feature that flashes the aiming point 10 times when low battery power is detected. The operator will have several hours of operating time in this mode before the sight is rendered inoperable without a battery change.

### Power-Saving Mode (Motion Sensor Technology™)

After the optic has been completely at rest for 5 minutes the sight transfers to sleep mode, thus nearly eliminating all battery drain. Upon any movement of the optic, the system powers up the LED to the last known setting. The unit will flash 10 times before automatic power off. The motion sensor will NOT reactivate the DeltaPoint Pro if it has been turned off manually.

## Installation

**Note:** If you are installing the DeltaPoint Pro on a milled slide, the mount base & dovetail are not required.

Installation on most handguns requires the use of one of the optional mount bases (sold separately) . Leupold recommends utilizing a qualified gunsmith to press/remove the rear sight from your handgun. Once the rear sight has been removed, the appropriate dovetail replaces the rear sight, with the part number facing up. Some installations (Kimber / Smith & Wesson M&P) require the use of the set screws to be placed in the dovetail to hold it in place and the M4x.7x15.8mm Torx® screws will fasten into the dovetail plate extension.

The corresponding mount base for your pistol is placed on top of the slide and over the dovetail with the flat part number side facing up through the slot in the base. Once the dovetail and mount base have been placed on the slide, the DeltaPoint Pro is placed on top of the base. The four holes in the bottom of the DeltaPoint Pro will align with the four short posts on the mount base and secure into the dovetail using the two included M4x.7x15.8mm Torx® screws ( Figure 1). Secure the screws by applying 25 inch pounds of torque. Securing these screws creates a press-fit and will hold the DeltaPoint Pro firmly in place. Call Leupold customer service for details specific to your handgun. For rifle/shotgun applications, the Cross-Slot Mount allows fast and easy mounting on Weaver-style or Picatinny bases/rails.

(Figure 1)

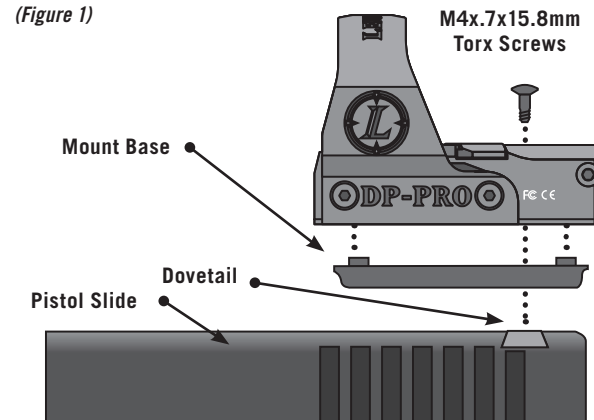

## Smith & Wesson® Revolver Mount

(For use with Smith & Wesson Classic pre-drilled and tapped K, L, N & X frame revolvers, including .500)

Remove the rear sight and retain the sight and all mounting hardware for future use if necessary. Place the insert (10A) into the mount base (10B) and set both pieces on the revolver as shown above. Install the two 6-48x .210 screws through the dovetail insert and into the last two tapped holes, nearest the hammer in the frame of the revolver (Figure 2). Tighten to 20 inch pounds.

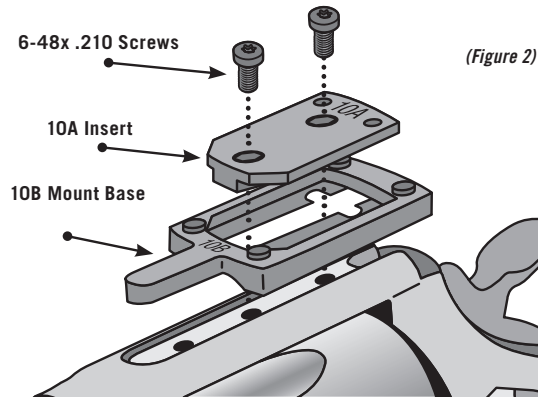

(Figure 2)

Place the DeltaPoint Pro on the mount base so that the four holes in the bottom of the DeltaPoint Pro will align with the four short posts on the mount base and the screw holes in the sight and mount base align (Figure 3), then secure the sight with the two M4 x 14mm screws using 20 inch pounds of torque.

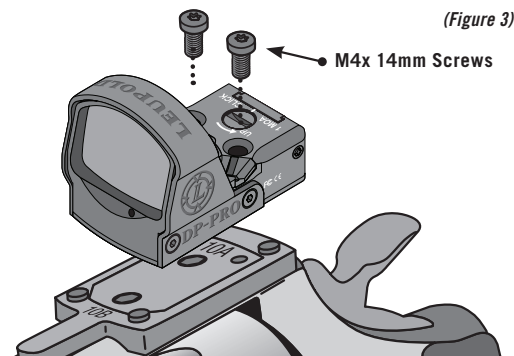

(Figure 3)

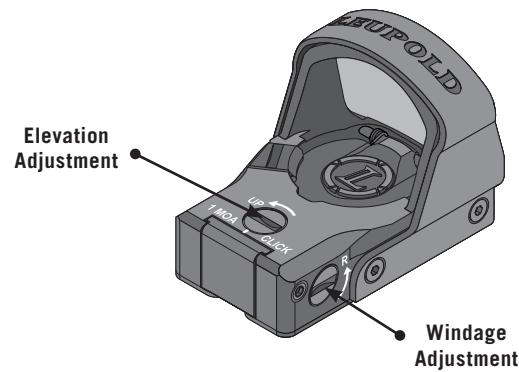

## Operating Procedure Elevation and Windage Adjustment

Separate controls for the elevation and windage adjustments are found on the top and right side of the sight. Turn the UP or "R" (RIGHT) screws with a screwdriver, cartridge rim or coin. The windage adjustment mechanism has limit stops at both ends.

### Zeroing the Point-of-Impact

The DeltaPoint Pro windage and elevation screws move the point of impact 40 MOA (10" @ 25 yds) per revolution of the dial (1 MOA per click).

### Boresighting the DeltaPoint Pro Reflex Sight

To make the boresighting process easier, Leupold recommends placing the eye near the DeltaPoint Pro while making windage/elevation adjustments. As with any boresighting procedure, be sure to follow all safety precautions prior to boresighting, and make sure the boresighter has been removed from the barrel prior to loading the magazine or chamber.

#### Caution: Boresighting the DeltaPoint Pro

Verify that the magazine of the firearm has been removed or emptied, and that there is not a round in the chamber. Only after double checking the firearm, verifying it is empty and safe, should you proceed with the boresighting process. Be sure to remove the boresighter from the the barrel prior to loading the magazine or chamber.

## DeltaPoint Pro Accessories (sold separately)

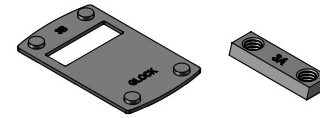

### DeltaPoint Pro All Mounts Kit (120057)

- Allows the DeltaPoint Pro to be installed on many of today's popular handguns.
- (10) Mount Bases with dovetails

*Beretta® 92/96 /90-TWO/Taurus PT99*

*1911 Standard*

*Glock®*

*Sig Sauer® P226*

*Springfield® XD*

*CZ® 75*

*HK® HK P2000*

*Kimber® Fixed/Adjustable*

*Smith & Wesson® M&P / Classic*

### DeltaPoint Pro Reversible Cross-Slot Mount (120056)

- For installing the DeltaPoint Pro on Picatinny rails and Weaver-style bases.

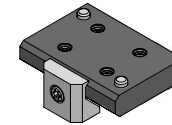

### DeltaPoint Pro Cross-Slot Riser (120059)

- Used in conjunction with the DeltaPoint Pro Reversible Cross-Slot Mount to achieve proper height and match alignment of cheek-to-stock weld when installing the DeltaPoint Pro on an AR style rifle.

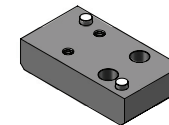

### DeltaPoint Pro Rear Iron Sight (120058)

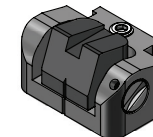

- Allows for co-witnessing through the DeltaPoint Pro on a handgun.
- Faster reticle acquisition and a sure-fire backup in case of battery failure. A taller front sight is required when using the Rear Iron Sight.

## Leupold Gold Ring™ Full Lifetime Guarantee

If any Leupold Gold Ring product is found to have defects in materials or workmanship, Leupold & Stevens, Inc. will repair, or if repair is not possible, either replace the product or refund the purchase price, whichever you prefer. FREE. Even if you are not the original owner. No warranty card is required. No time limit applies. This warranty excludes electronic components, which are subject to the limited two-year warranty below.

## Leupold Gold Ring Electronics Limited Two-Year Warranty

This warranty covers any defects in materials and workmanship in the electronic components of illuminated riflescopes/sights, flashlights, flashlight components, RX Rangefinders, GX Rangefinders, Pin Caddie Rangefinder, RCX Cameras and Vendetta Archery Rangefinder. This warranty lasts for two years from the date of purchase. If, during that two-year period, these products are found to have defects in materials or workmanship, Leupold will repair, or if repair is not possible, replace the product, free of charge.

### Warranty Exclusions

Unfortunately, these warranties do not apply if the product has been modified, misused or has been damaged by accident, abuse, or misapplication. To ensure this doesn't happen to you, contact Leupold Product Service before having any work or repairs done to your valuable Leupold optics. Call 1-800-LEUPOLD or (503) 526-1400. If your Leupold product fails to perform in any way, please contact a Leupold Product Specialist within our Product Service department to determine if the problem can be solved without sending the product to Leupold. Many times, the problem can be solved without sending the product to us. Leupold Technical Service will assist you with the problem in the best and most efficient manner.

## To Reach Leupold Product Service

**Phone:**  
7:00 a.m. - 4:30 p.m. PST M-F 1-800-LEUPOLD  
or (503) 526-1400

**Fax:**  
24 hours a day, 7 days a week  
(503) 352-7621

**E-mail:**  
productspecialist@leupold.com

**Parcel Service**  
Leupold Product Service  
14400 NW Greenbrier Parkway  
Beaverton, OR 97006-5791 USA

**Postal Service**  
Leupold Product Service  
P.O. Box 688  
Beaverton, OR 97075-0688 USA

LEUPOLD, GOLDEN RING, MARK 4, the Golden Ring design, the circle-L reticle logo design, and various other marks are registered trademarks of Leupold & Stevens, Inc. All marks, including corporate logos and emblems, are subject to Leupold's rights and may not be used in connection with any product or service that is not Leupold's, or in any manner that disparages or discredits Leupold, or in a manner likely to cause confusion.

Certain other trademarks used in connection with Leupold products and services are the property of their respective owners, and are used with permission. BOONE AND CROCKETT CLUB and BOONE AND CROCKETT are registered trademarks of the Boone and Crockett Club. RMEF and ROCKY MOUNTAIN ELK FOUNDATION are registered trademarks of the Rocky Mountain Elk Foundation. ADVANTAGE TIMBER and ADVANTAGE TIMBER HD are trademarks or registered trademarks of Jordan Outdoor Enterprises Ltd. MOSSY OAK BREAK-UP, MOSSY OAK BRUSH, MOSSY OAK OBSESSION, and MOSSY OAK TREESTAND are trademarks or registered trademarks of HAAS Outdoors, Inc. A.R.M.S. is a registered trademark of Atlantic Research Marketing Systems, Inc.

We reserve the right to make design and/or material modifications without prior notice.

Copyright © 2015 Leupold+Stevens, Inc. All rights reserved.



**LEUPOLD+STEVENS, INC.**  
PO Box 688 Beaverton, Oregon 97075-0688

www.leupold.com  
1-800-LEUPOLD (538-7653)

Part #120278 Artwork #120279D

